

Campus Highlands Homeowners Association
Pre-Approved Fence Stains, Construction & Maintenance
Content revised 4/05; documents combined 7/07; revised for updated stain
12/2018

WHEREAS Article 10 of the Declaration of Protective Covenants, Conditions & Restrictions of Campus Highlands (C.C. & R.s) grants the Board of Directors the authority to review and approve or disapprove any exterior alterations or improvements.

To efficiently exercise that authority, a need has arisen to provide authorized fence stain colors to the residents of Campus Highlands.

Be advised that failure to adhere to these regulations may require owners to re-stain. Therefore

LET IT BE RESOLVED, effective December 1, 2018 and until otherwise modified;

- a) The Board establishes the following list of fence stains and colors.
 - Sherwin Williams SuperDeck Natural Clear/Transparent Cedar stain #355 (new fencing or over existing clear/transparent fencing)
 - Sherwin Williams SuperDeck Solid Cedar Stain #3034
- b) Fences currently painted with Parker Saturn White are grandfathered under this Resolution. However, white will not be authorized for any new fences after June 3, 2005 and may not be applied over existing stains.
- c) Painting of fences to color match the home or trim is not permitted.

Fence Construction Guidelines

This is an update to the amended Fence Guidelines as written by the Architectural Committee. Refer to diagram for additional information.

- 1. Accepted fence design requires that top rails frame into the side of the posts. Posts will have cap plates on top. This design provides pleasing aesthetics and protects the end grain of the posts from water damage.
- 2. Fence boards must be 1x6, with finished thickness of not less than 5/8”.
- 3. These guidelines affect new fence construction or replacement of deteriorated fencing.

Fence Maintenance Responsibility

Where fences separate two homes, each homeowner is responsible for maintaining their respective side.

Homeowners whose fence borders undeveloped lots (such as common or rough-cut areas) are responsible for maintaining both sides of said fence.

Homeowners whose fence borders FWSD property are responsible for maintaining their side of said fence.

Maintenance of fences in undeveloped or common areas, that do not border a developed lot, will be the responsibility of the Campus Highlands Homeowner’s Association, as outlined in the CC&R.

Revision signed this _____ day of _____, 200__

President – Board of Directors

Secretary – Board of Directors

**Campus Highlands Homeowners Association
Amendment
Fence Guidelines**

Fence Construction Guidelines (see attached copy of diagram)

This is an update to the amended Fence Guidelines as written by the Architectural Committee.

1. Accepted fence design requires that top rails frame into the side of the posts. Posts will have cap plates on top. This design provides pleasing aesthetics and protects the end grain of the posts from water damage.
2. Fence boards must be 1x6, with finished thickness of not less than 5/8".
3. These guidelines affect new fence construction or replacement of deteriorated fencing.

Fence Maintenance

Where fences separate two homes, each homeowner is responsible for maintaining their respective side.

Homeowners whose fence borders undeveloped lots (such as common or rough-cut areas) are responsible for maintaining both sides of said fence.

Maintenance of fences in undeveloped or common areas, that do not border a developed lot, will be the responsibility of the Campus Highlands Homeowner's Association.

The Amendment to the Fence Guidelines will be effective June 3, 2005 and until otherwise modified;

Signed this 1 day of JUNE, 2005

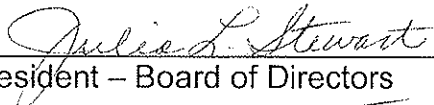

President – Board of Directors



Secretary – Board of Directors

Recorded in the Book of Minutes this 1 day of June, 2005



Secretary – Board of Directors

Secretary – Board of Directors

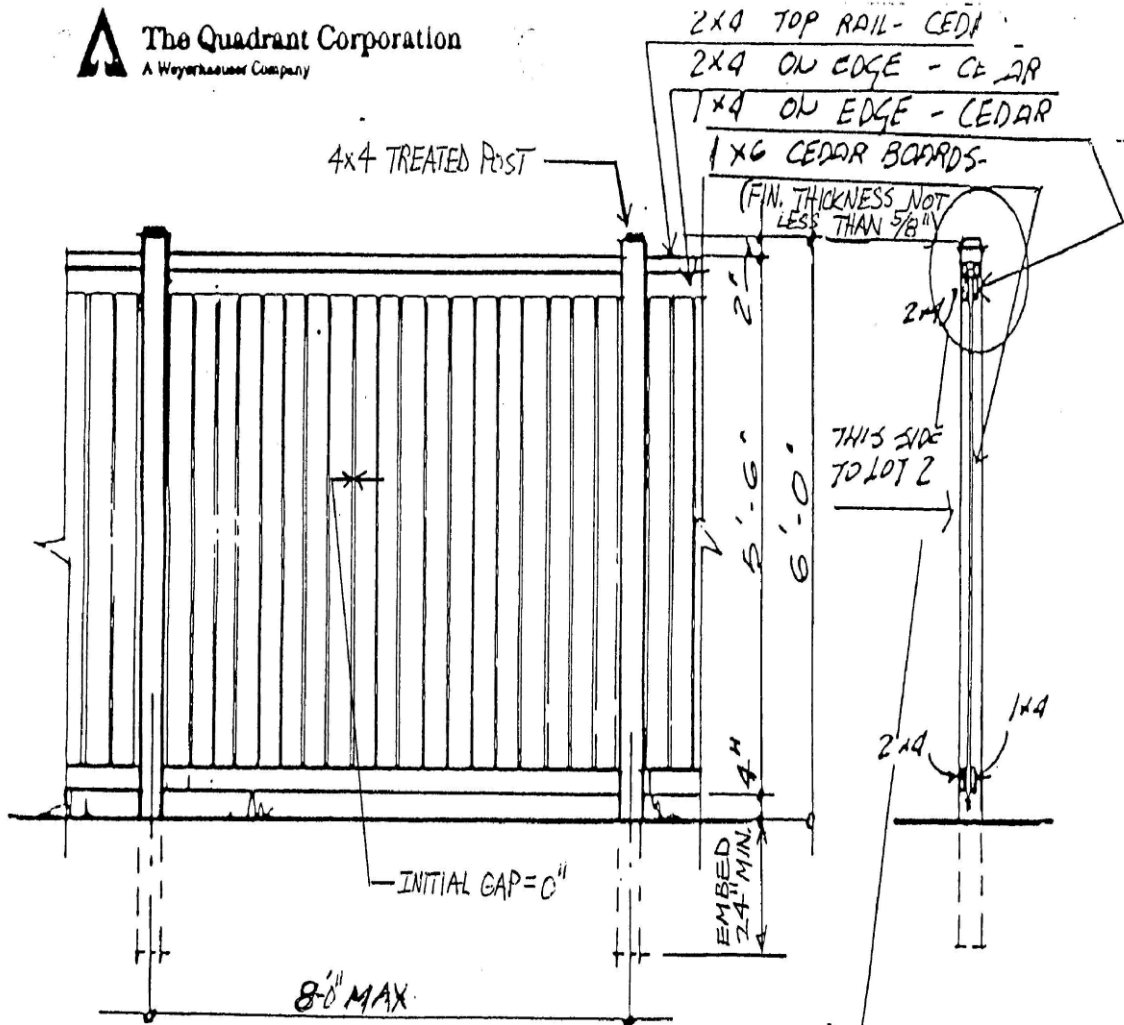

CAMPUS HIGHLANDS
STANDARD FENCE DETAIL
(EFFECTIVE 4-1-93)